

# Mind FLEX

## DUEL™

### Game

8 to Adult  
1-2 Players

## INSTRUCTION MANUAL

**IMPORTANT:** Please read the entire Quick Start section before playing any games.

[www.mindflexgames.com](http://www.mindflexgames.com)

Keep these instructions for future reference as they contain important information.

Requires 4 'C' alkaline batteries and 6 'AAA' alkaline batteries (Not Included).

GET READY TO CONTROL THE ACTION AS YOU NEVER HAVE BEFORE – WITH THE POWER OF YOUR MIND!

Just put on the Mindflex Duel™ headsets and your own **brainwaves** will move a ball up and down on a cushion of air or push it across the console. Concentrate and the ball will rise or move forward, relax and it will descend or move backward – it's literally mind over matter!

## CONTENTS

Mindflex Duel™ includes the following components:

1 Game Console  
2 Headsets  
4 Balls  
1 Flex Tower

1 Wind Wheel  
1 Score Wall  
1 Flip Frame  
1 Canon  
1 Basket  
1 Instruction Sheet

### HANDLE FOAM BALLS WITH CARE.

Do not press, crush or squeeze the foam balls, or you may damage their ability to float.

Keep them safe by storing them in the compartment on the underside of the console.

## THE CONSOLE

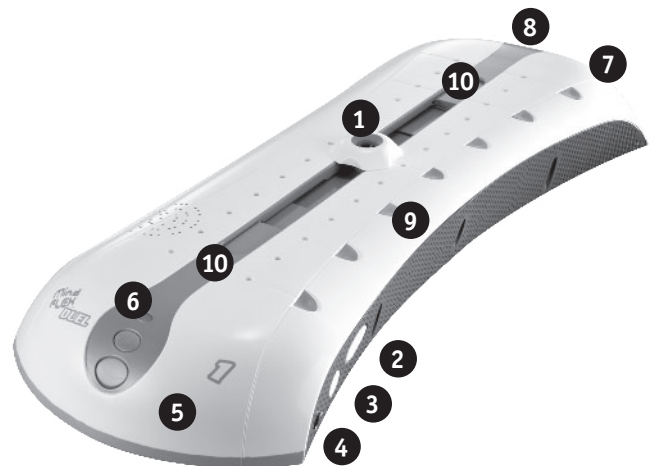

1. Puck (Fan Nozzle)
2. Toggle Button
3. Enter Button
4. On/Off Switch
5. Player One's Side (Orange #1)
6. Player One's Concentration Meter
7. Player Two's Side (Green #2)
8. Player Two's Concentration Meter
9. Marker Lights
10. End Zones
11. Foam Ball Storage Compartment (Bottom)
12. Battery Compartment (Bottom)

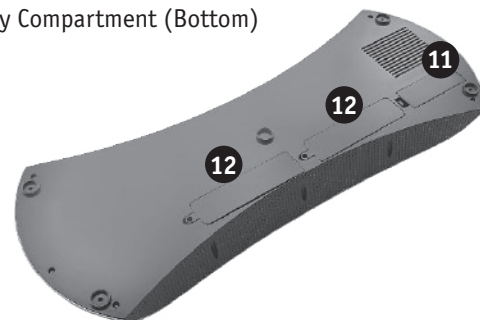

Bottom of Console

## THE HEADSET

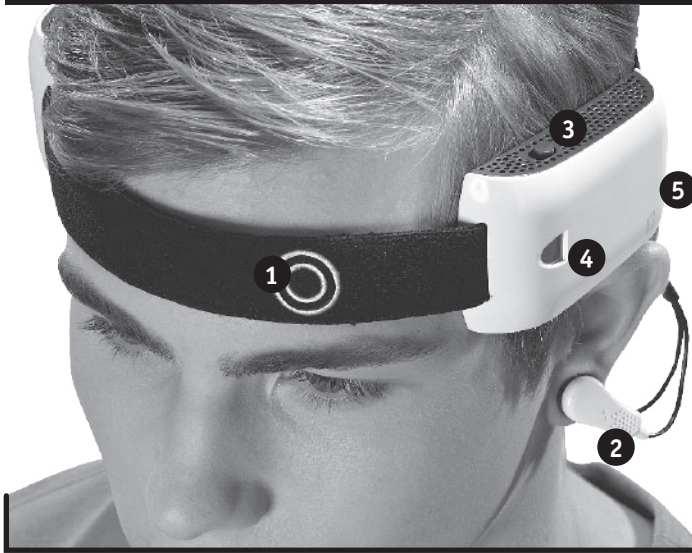

- |                    |   |
|--------------------|---|
| 1. Forehead Sensor | 4. Power Light                          |
| 2. Ear Clip        | 5. Player Number                        |
| 3. On/Off Switch   | 6. Adjustable Buckle (on strap in back) |

## BATTERY INSTALLATION

### Console

1. Open the two battery covers with Phillips head screwdriver (not included).

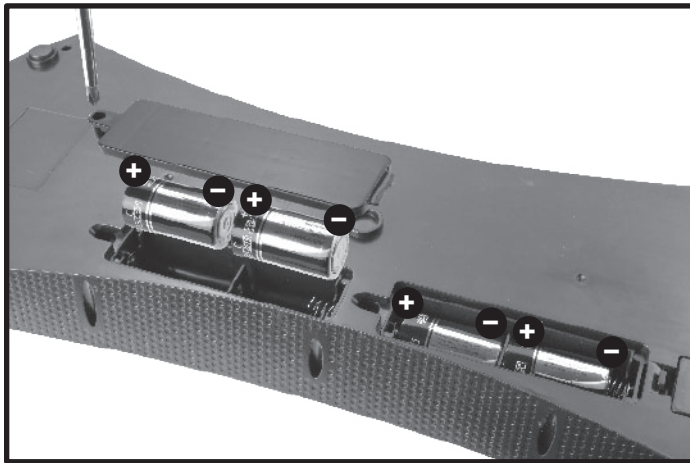

2. Insert 4 'C' alkaline batteries as shown.
3. Replace battery covers and tighten the screws.

For best performance, use only alkaline batteries.

Replace console batteries when console lights dim, sound becomes distorted or ball can no longer achieve a maximum height of 5 inches when all 3 concentration meter lights are lit. The console will say "Replace batteries in console" when power is running low.

## Headsets

1. Open battery cover with Phillips head screwdriver (not included).

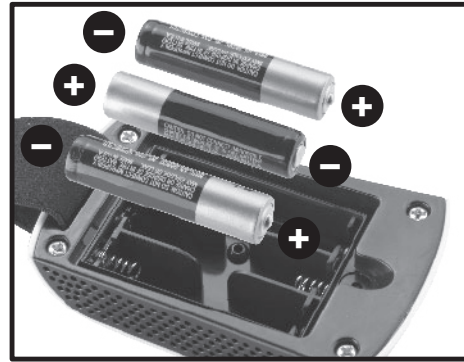

2. Insert 3 'AAA' alkaline batteries as shown.
3. Replace battery cover and tighten the screw.

When a headset's power light blinks, the headset batteries are running low. The console will say, "Player One/Two, replace batteries in headset."

## QUICK START

To familiarize yourself with Mindfex Duel™, try a few exercises in Freestyle mode. Just follow the steps below.

## PUTTING ON HEADSET

### One Player

1. When only one person is playing, put on the headset marked "1" as shown above. Make sure the **forehead sensor** located under the colored rings is positioned above your **left eye**, flat against your forehead, with no hair between your skin and the sensor.

**IMPORTANT:** When playing Freestyle mode or any single-player game, you **MUST** wear the headset marked "1" – this is the headset that the console will attempt to contact. If you are using headset "2" when the console tries to connect, it will say, "Player One, turn on the headset." If you hear this, make sure you are wearing headset "1" and that it is turned on. The console will continue to prompt you to "turn on the headset" until it can communicate with headset "1."

2. If the headset does not fit comfortably against your forehead, use the buckle on the back of the headset to adjust for a snug fit.
3. Attach the ear clip to your ear lobe so the metal sensor is flat against your skin.
4. While sitting as still as you can, turn on the headset – the headset's Power Light will come on.

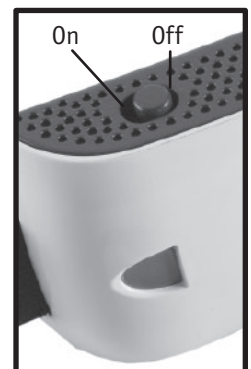

### Helpful Hints

1. Before putting on the headset, be sure to remove hats, ponytails, hairclips or anything else that might get in the way, and brush the hair from your forehead.
2. Before attaching the ear clip, remove earrings.

## Two Players

If two people are playing, the first player should put on the headset marked "1" and the second player should put on the headset marked "2," both following the steps described above.

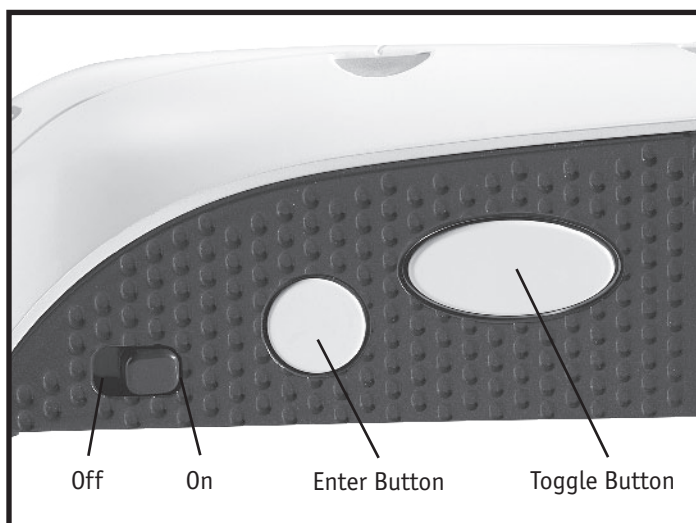

## TURNING ON CONSOLE

1. Position yourself at the end of the console labeled with an orange "1" (Player One's side) and turn on the console.
2. When the console says "Select Game," press the TOGGLE BUTTON until you hear "Freestyle."
3. Press the ENTER button to confirm your choice of "Freestyle." The fan nozzle – called the "puck" – will calibrate and move to Player One's side of the console.

**IMPORTANT:** After you select a game, the puck will calibrate by moving across the console. Do not touch the puck while it is moving or you will affect the game's performance.

4. It may take a few seconds for the console to communicate with the headset. Just remain still until it does so. Once a connection is established, the console will say, "Ready – begin."

### CONNECTION PROBLEMS

Whenever the headset fails to read a player's brainwaves, the console will call out the player and say, "Check headset sensor." If this happens during a game, the game timer will pause until the signal is restored.

Refer to the TROUBLESHOOTING section for tips on connection problems.

## CONTROLLING THE BALL

Once in Freestyle mode, try each of the practice exercises below to familiarize yourself with controlling the ball. Place a ball on top of the puck, but **do not** put any obstacles on the console yet.

The concentration meter (3 lights) on the face of the console will display your level of concentration.

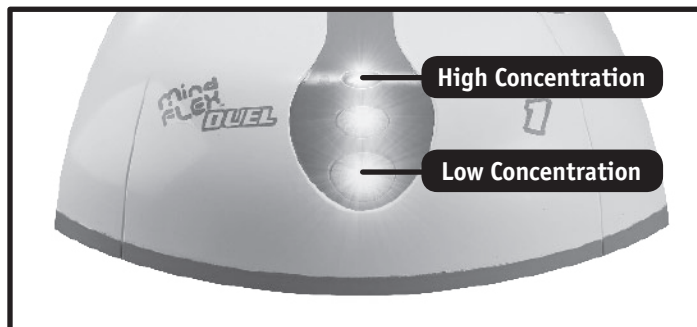

## RAISING THE BALL (HIGH CONCENTRATION)

The higher your concentration, the higher the ball will float – up to a height of approximately 5 inches.

### Tips for Increasing Concentration

- Relax your face – try not to move any muscles in your face.
- Stare at the ball. Concentrate all of your attention on it.
  - Picture the ball rising.
- Focus your attention on the exact spot you want to see it reach.
  - Imagine pushing the ball up with your mind.
  - Do math problems in your head.
  - Think the same thought over and over.
- Everyone is different, so find out what works best for you!

**Exercise #1:** Raise the ball as high as you can and try to hold it there for three seconds.

## LOWERING THE BALL (LOW CONCENTRATION)

By relaxing your concentration, the ball will descend.

### Tips for Lowering Concentration

- Try to clear your mind.
  - Relax your body.
  - Take deep breaths.
- Close your eyes for a moment then open them and look at different parts of the console without focusing on anything.
  - Think about sleeping.
  - Think about a peaceful, relaxing place.
- Again, discover what techniques work best for you!

**Exercise #2:** Lower the ball. Try to hold the ball in place for three seconds.

**Exercise #3:** Raise and lower the ball several times in a row.

## MOVING FORWARD OR BACKWARD (TOGGLE BUTTON)

To move the ball – and the puck – forward or backward along the console, press either end of the TOGGLE button.

**Exercise #4:** Concentrate until the ball is floating as high as you can get it. Press the far side of the TOGGLE button and move the puck to the other end of the console, trying to keep the ball at the same height.

**Exercise #5:** Once you reach the far end, relax your thoughts until the ball is floating as low as you can get it. Now press the near side of the TOGGLE button and move the puck back toward you, maintaining the low height of the ball.

**Exercise #6:** Press ENTER to end the game.

Congratulations! By completing this Quick Start you have begun to master the power of your mind! Now it's time to tackle the obstacles!

Plug the flex tower into its white base then attach it to the console. Make sure the flat section of the base faces the track.

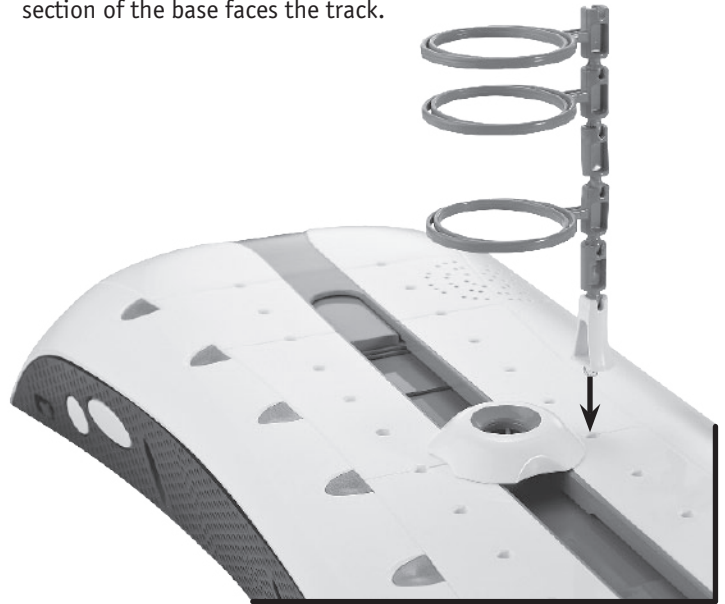

## OBSTACLES

It takes serious mental focus to navigate the Mindflex Duel™ course. Each obstacle you face along the way will challenge your concentration skills with a unique “mental block.”

### FLEX TOWER

The flex tower has multiple segments that can be plugged together in different combinations to make the tower longer or shorter. You can have up to 3 hoops on the tower at a time. Use the spacing segments to spread out the position of the hoops as needed.

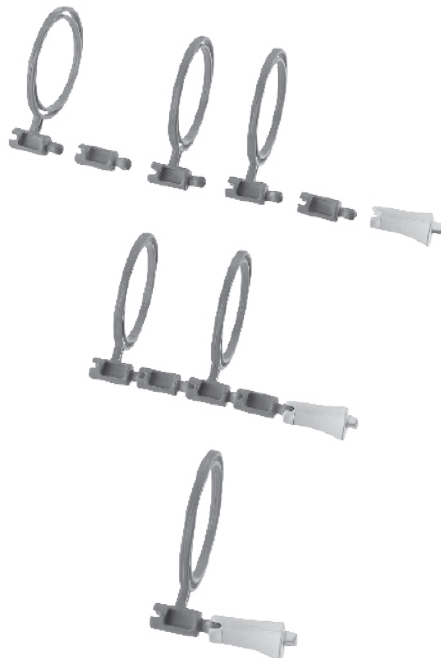

Further customize the flex tower by bending it to whatever angle you desire. Just be sure that the hoops are centered above the path of the track.



### FLIP FRAME

Snap one or both of the shelves into the sockets on the stands. The shelves can be rotated to create different obstacles that must be overcome.

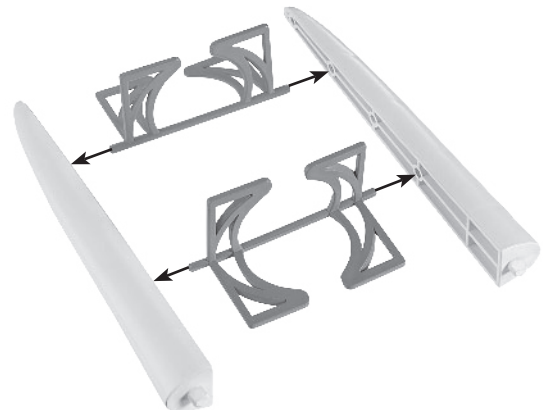

Plug the pegs on each stand into the console.

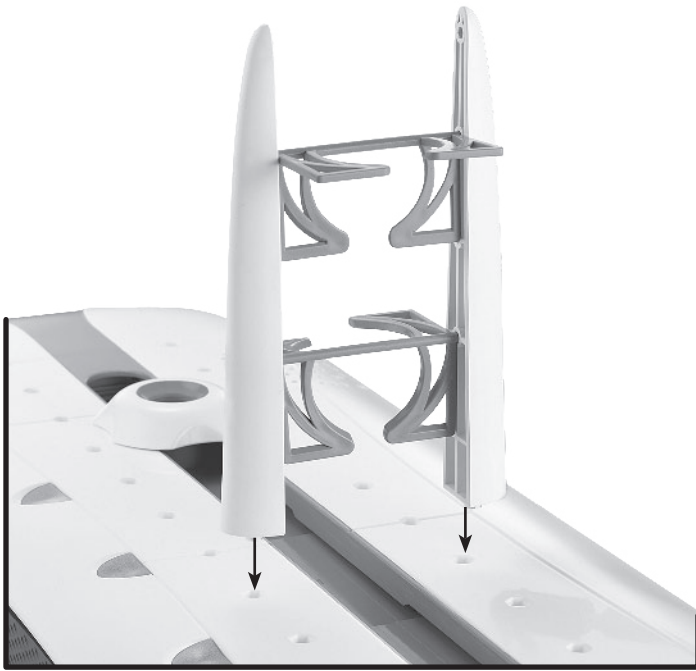

The shelves can be rotated to create different obstacles to overcome. You must travel over or under the shelves – the ball will not pass through the semicircles.

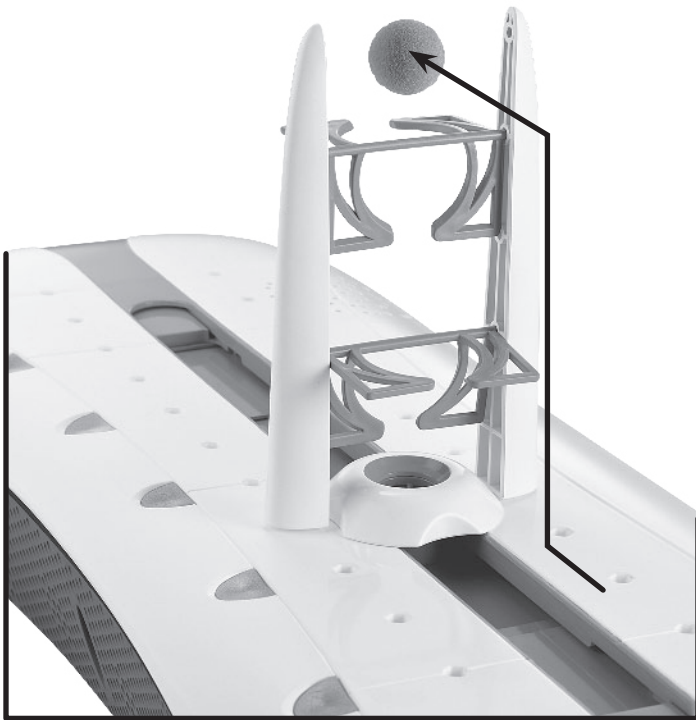

For best performance, position the shelves at 90-degree angles so that one shelf is parallel with the console. For a greater challenge, angle the shelves any way you want.

## BASKET

Line up the tabs in the basket with the slots in the basket's base then plug them together. Snap one U-hoop into the slots on both the blue end and the white end of the basket.

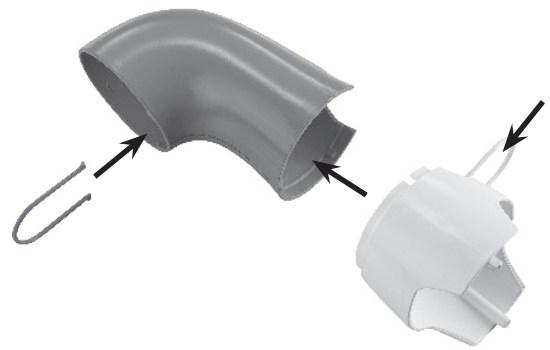

Attach the basket to the console so the upper opening points **toward** Player One's side of the console.

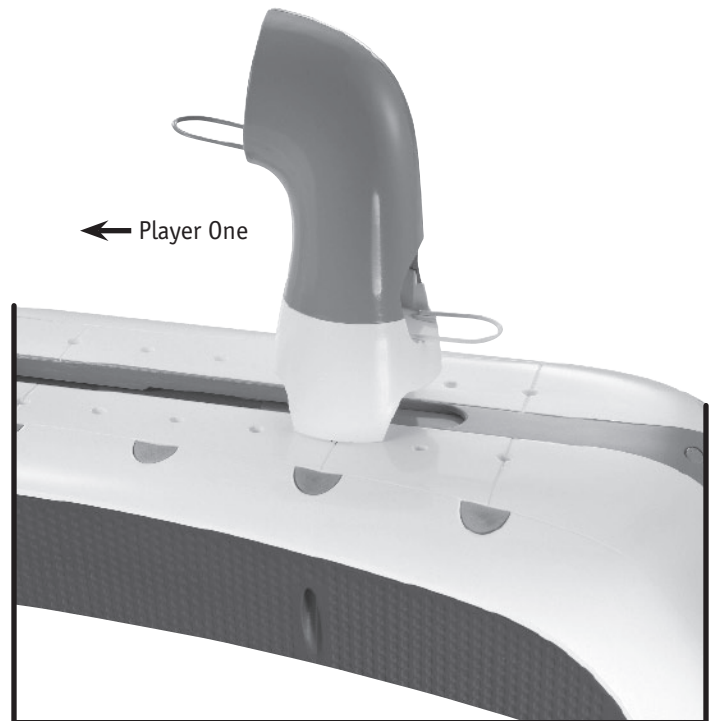

Navigate this obstacle by traveling through the upper part of the basket. Lower the ball onto the top U-hoop and it will roll down the tube onto the U-hoop at the bottom. Move the puck forward to pick up the ball from the other side.

## CANNON

Line up the notches in the two halves of the barrel and plug them together. Next, plug the completed barrel into the cannon base. Attach the assembled cannon to the console.

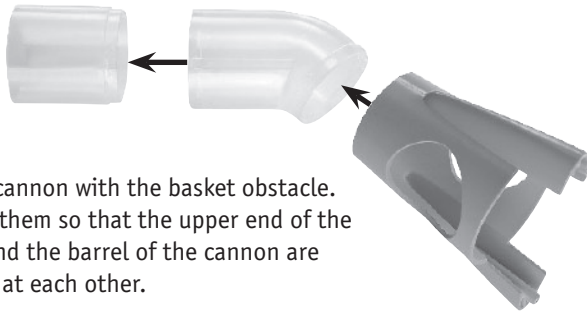

Use the cannon with the basket obstacle. Position them so that the upper end of the basket and the barrel of the cannon are pointing at each other.

Move the ball through the holes in the cannon base then concentrate to launch the ball into the basket!

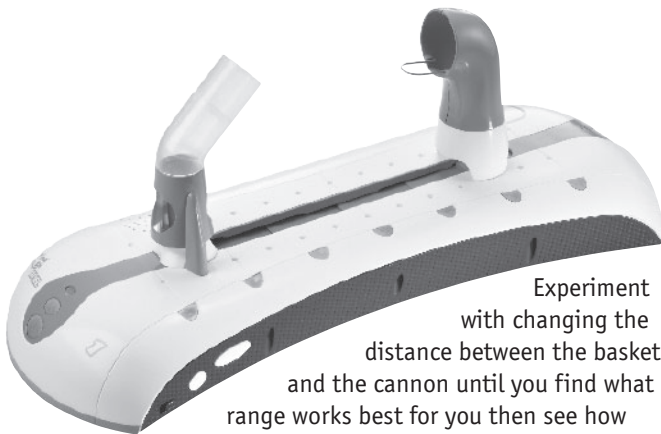

Experiment with changing the distance between the basket and the cannon until you find what range works best for you then see how many baskets you can make!

If the ball consistently overshoots the basket, remove one section of the cannon barrel. This allows you to position the basket closer to the cannon.

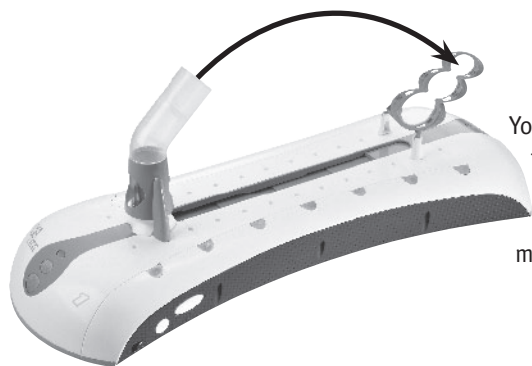

You can also use the cannon with the score wall. Go for maximum points!

## For a Greater Challenge

Use the cannon as a stand-alone obstacle. Try to navigate through its base without getting shot out.

## SCORE WALL

Make sure the two white bases are attached to the score wall then plug them into the console. The flat side of each base must be facing the track, and the numbers on the score wall should be facing Player One's side. For best performance, position the score wall as straight (up and down) as possible.

Maneuver the ball through any of the holes on the score wall. The smaller the hole, the greater the challenge and the more points it's worth! Keep track of your points on a separate piece of paper.

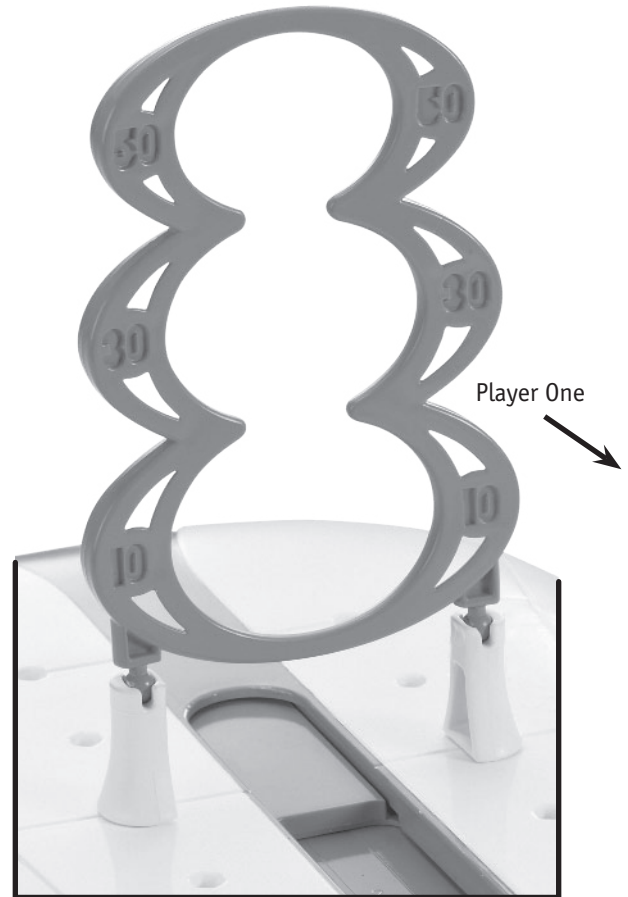

When playing Basketblaster™, you can use the score wall instead of the basket. Position the score wall opposite the cannon, tilt it at a 45-degree angle and fire away.

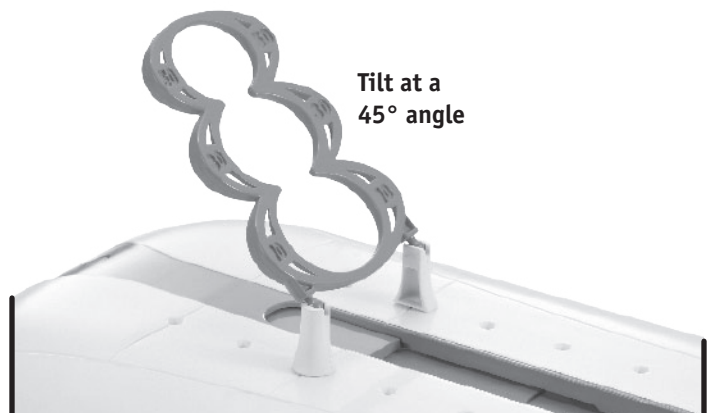

## WIND WHEEL

Plug both pegs of the wind wheel into the console so the numbers on the wheel face Player One's side. Air from the fan will cause the wheel to spin in a clockwise direction.

To pass this obstacle, move the ball next to the wheel. When it starts to spin, carefully move the ball forward through one of the openings. The smaller the opening, the greater the challenge. The higher your concentration, the more the fan will spin.

**TIP:** Raise the ball until it is higher than the white crossbar – be careful not to get the ball too close or the paddles will knock it away. Once the desired point-ring approaches the ball, start lowering the ball to the height of the white bar. This will cause the wheel to slow down, allowing you to move the puck forward. Move the ball **under** the white bar and through the desired ring.

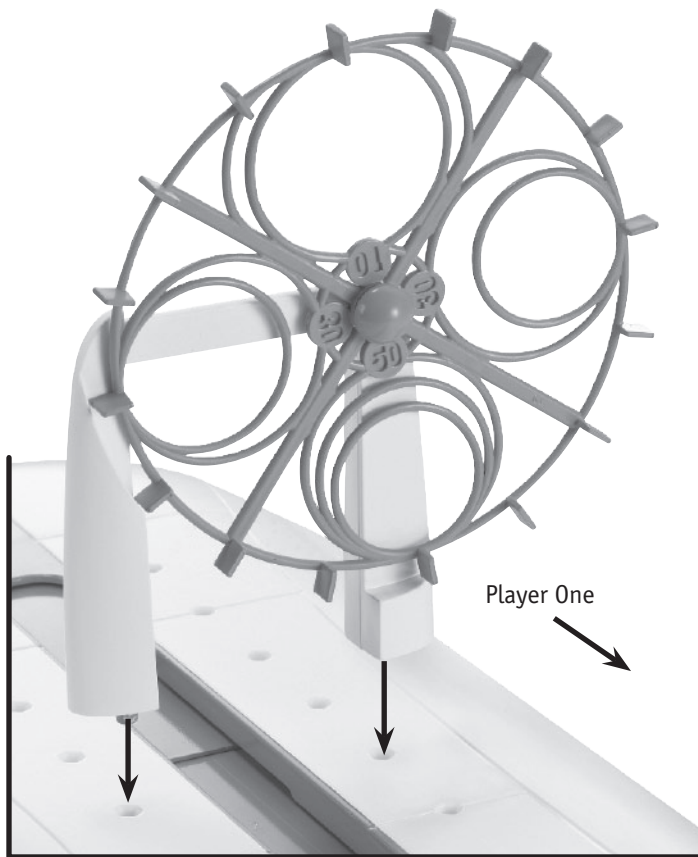

## BUILDING A COURSE

Create whatever course you can imagine by positioning obstacles in whatever order you want.

When you build an obstacle course, follow these simple guidelines:

1. Be sure to leave at least two empty spaces between each obstacle.

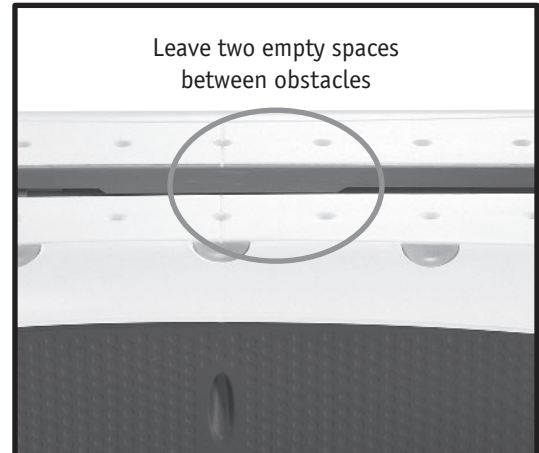

2. When using the cannon and basket together, it is recommended that you use both pieces of the cannon barrel if the cannon and basket are **more** than 5 spaces apart. If they are **less** than 5 spaces apart, you should only use 1 piece of the cannon barrel.

# THE GAMES

Now that you've familiarized yourself with controlling the ball and the different obstacles, it's time to try out the 6 different games!

## The Game Menu

After putting on the headset(s) and turning on the console (as described in the Quick Start section), the console will direct you to "Select game." The light above the TOGGLE and ENTER buttons will begin to flash, indicating that you are in the Game Menu and need to make some choices.

## Making Selections

Press the TOGGLE button to cycle through a list of games then press the ENTER button to confirm your choice.

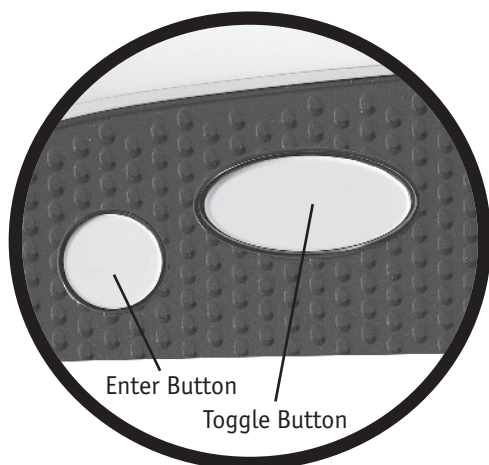

**Note:** Depending on the game you choose, you may also be prompted to select GAME MODE and DIFFICULTY LEVEL.

## Adjusting the Volume

Press and hold down the ENTER button then use the TOGGLE button to cycle up and down through 5 volume settings. When you reach the desired volume, release both buttons.

## Canceling Selections

If you wish to cancel a choice or end a game, press and hold the ENTER button for 3 seconds until you return to the Game Menu and you hear "Select Game."

## Playing Again

At the end of some games, the console will ask, "Play again?" Use the TOGGLE button to select either "Yes" or "No" then press ENTER.

## Sleep Mode

After about 4 minutes of inactivity, your game will end and the console will enter **Sleep Mode** to conserve power (current game information will not be saved). Press the ENTER button to reactivate the console and return to the Game Menu.



# FREESTYLE

**Number of Players:** 1 (Player does not need to select)

**Modes:** Solo

**Object:** Practice your concentration skills with no time limit.

1. Put on Headset 1 as described in the Quick Start section.
2. Position yourself at Player One's side of the console.
3. Place the ball on the puck.
4. Turn on the console.
5. When the console says, "Select game," press the TOGGLE button until you hear "Freestyle," then, press ENTER.
6. The puck will calibrate then move into position at Player One's end of the console.
7. The console will say, "Ready? Begin." (If you experience connection problems, refer to the Troubleshooting section.)
8. The ball will now react to your concentration level by moving up and down. Move the ball forward and back with the TOGGLE button.
9. Practice controlling the ball or using different obstacles. You can also use "Freestyle" mode to make up your own games!
10. When you want to exit "Freestyle," press the ENTER button to return to the Game Menu.



## POWER PUSH

**Number of Players:** 2 (Cannot be played by a single player)

**Modes:** Competitive

**Object:** The first player to push the ball into the end zone on their opponent's side of the console wins the game.

1. Player One puts on Headset 1 and Player Two puts on Headset 2 as described in the Quick Start section.
2. Players position themselves at opposite ends of the console – Player One on the side marked with an orange "1" and Player Two on the side marked with a green "2."
3. Do NOT set up any obstacles.
4. Place the ball on the puck.
5. Turn on the console.
6. When the console says, "Select game," press the TOGGLE button until you hear "Power Push," then press ENTER.
7. The puck will calibrate then move into position at the center of the console.
8. The console will say, "Ready? Begin."
9. Player One and Player Two both concentrate to push the ball toward their opponent's end of the console – the player with the higher concentration will move the ball.
10. The first player to push the ball all the way into the end zone on their opponent's side of the console is the winner.



## MENTAL MARATHON® 2.0

**Number of Players:** 1-2

**Modes:** Solo, Competitive, Cooperative

**Object:** Travel from one end of the console to the other as quickly as you can.

### SOLO MODE

1. Put on Headset 1 as described in the Quick Start section.
2. Position yourself at Player One's side of the console.
3. Set up the obstacle course as desired.
4. Turn on the console.
5. When the console says, "Select game," press the TOGGLE button until you hear "Mental Marathon® 2.0," then press ENTER.
6. When the console says, "Select mode," press the TOGGLE button until you hear "Solo," then press ENTER.
7. The puck will calibrate then move into position at Player One's side of the console.
8. Quickly place the ball on the puck.

9. The console will say, "Ready? Begin."
10. Move the ball to the opposite side of the console as quickly as you can. Use the TOGGLE button to move the puck forward or backward, and use your concentration to move the ball up and down.
11. If the ball falls out of the airflow, place it back on the puck at the point where it fell off.
12. When you reach the far end of the track – called the **end zone** – the console will announce your time.



## COMPETITIVE MODE

1. Player One puts on Headset 1 and Player Two puts on Headset 2 as described in the Quick Start section.
2. BOTH players position themselves at Player One's side of the console.
3. Set up the obstacle course as desired.
4. Turn on the console.
5. When the console says, "Select game," press the TOGGLE button until you hear "Mental Marathon® 2.0," then press ENTER.
6. When the console says, "Select mode," press the TOGGLE button until you hear "Competitive," then press ENTER.
7. The puck will calibrate then move into position at Player One's side of the console.
8. Quickly place the ball on the puck.
9. The console will say, "Player One – ready? Begin."
10. Player One moves the ball to the end zone at the opposite side of the console as quickly as he can.
11. If the ball falls out of the airflow, place it back onto the puck at the point where it fell off.
12. When Player One reaches the end zone, the console will announce his time.
13. The puck will again move into position at Player One's side of the console.
14. The console will say, "Player 2 – ready? Begin."
15. Player Two then moves the ball to the opposite side of the console as quickly as he can.
16. When Player Two reaches the end zone, the console will announce his time and then declare a winner based on player with the shortest time.

## COOPERATIVE MODE

This game is the ultimate challenge. When you've mastered everything else in Mindflex Duel™, then you're ready for this!

1. Player One puts on Headset 1 and Player Two puts on Headset 2 as described in the Quick Start section.
2. Players position themselves at opposite ends of the console – Player One on the side marked with an orange "1" and Player Two on the side marked with a green "2."
3. Set up the obstacle course as desired.
4. Turn on the console.
5. When the console says, "Select game," press the TOGGLE button until you hear "Mental Marathon® 2.0," then press ENTER.
6. When the console says, "Select mode," press the TOGGLE button until you hear "Co-op," then press ENTER.
7. The puck will calibrate then move into position at Player One's side of the console.
8. Place the ball on the puck then press ENTER.
9. The console will say, "Player One and Player Two, ready? Begin."
10. Player One uses his concentration to control the puck – high concentration will cause the puck to move forward more quickly, medium concentration will cause it to stop, and low concentration will cause it to move backwards. **NOTE:** If the puck gets "out of control," Player One can press and hold the TOGGLE button to stop the puck from moving. The player can then adjust his level of concentration. Releasing the button will return control to the headset.
11. At the same time, Player Two uses his concentration to control the height of the ball – the greater his concentration level, the higher the ball will float.
12. Working together, the players must move the ball from Player One's side of the console to Player Two's side as quickly as they can.
13. If the ball falls out of the airflow, place it back on the puck at the point where it fell off.
14. When the ball reaches the end zone on Player Two's side, the console will announce their time.

# RACE THE LIGHTS

**Number of Players:** 1-2

**Modes:** Solo, Competitive

**Difficulty Levels (Solo Mode Only):** Beginner, Intermediate and Advanced

**Object:** Race a blinking light to the opposite end of the console.

## SOLO MODE

1. Put on Headset 1 as described in the Quick Start section.
2. Position yourself at Player One's side of the console.
3. Place the ball on the puck.
4. Do NOT set up any obstacles.
5. Turn on the console.
6. When the console says, "Select game," press the TOGGLE button until you hear "Race the Lights," then press ENTER.
7. When the console says, "Select mode," press the TOGGLE button until you hear "Solo," then press ENTER.
8. When the console says, "Select difficulty," press the TOGGLE button until you hear "Beginner," "Intermediate" or "Advanced," then press ENTER for the desired level. The greater the difficulty, the faster the lights will move across the console.
9. The puck will calibrate then move to Player One's side of the console.
10. The console will say, "Ready? Begin"
11. As the first marker light on the console begins to flash, concentrate to push the puck toward the opposite side of the console as quickly as you can – the greater your concentration, the faster the puck will move.
12. The marker lights will light up in succession, advancing toward the opposite end of the console (the speed of the lights depends on the difficulty level selected).
13. If the ball falls out of the airflow, place it back on the puck where it fell off.
14. If the puck reaches the end zone on the opposite side of the console before the lights do, the console will say, "Player wins" then announce the time.
15. If the lights reach the end zone before the puck, the game ends and the console will say, "Game wins."

## COMPETITIVE MODE

1. Player One puts on Headset 1 and Player Two puts on Headset 2 as described in the Quick Start section.
2. Players position themselves at opposite ends of the console – Player One on the side marked with an orange "1" and Player Two on the side marked with a green "2."
3. Do NOT set up any obstacles.
4. Place the ball on the puck.
5. Turn on the console.
6. When the console says, "Select game," press the TOGGLE button until you hear "Race the Lights," then press ENTER.
7. When the console says, "Select mode," press the TOGGLE button until you hear "Competitive," then press ENTER.
8. The puck will calibrate then move to **Player One's** side of the console.
9. The console will say, "Player One – ready? Begin"
10. Player One concentrates to move the puck as quickly as he can to the end zone on Player Two's side of the console. The marker lights will FOLLOW Player 1, moving at the same speed and recording his time.
11. When Player One reaches the end zone on the opposite side of the console, the game will announce his time.
12. Player Two must now beat this time to win.
13. The puck will position itself at **Player Two's** side of the console.
14. The console will say, "Player Two – ready? Begin."
15. As the first marker light on the console begins to flash, Player Two concentrates to move the puck as quickly as he can toward **Player One's** side of the console.
16. The marker lights will continue to light up in succession. They will reach the opposite end of the console in the same amount of time that Player One just recorded.
17. If the lights reach the end zone before Player Two, the game ends and Player One wins.
18. If Player Two reaches the end zone before the lights, the game will announce his time.
19. The player with the fastest time wins.

# CORTEX COLLISION

**Number of Players:** 1-2

**Modes:** Solo, Competitive

**Object:** Concentrate to build up enough power to smash your way to the opposite end zone.

## SOLO MODE

1. Put on Headset 1 as described in the Quick Start section.
2. Position yourself at Player One's side of the console.
3. Place the ball on the puck.
4. Do NOT set up any obstacles.
5. Turn on the console.
6. When the console says, "Select game," press the TOGGLE button until you hear "Cortex Collision," then press ENTER.
7. When the console says, "Select mode," press the TOGGLE button until you hear "Solo," then press ENTER.
8. The puck will calibrate then move to Player One's side.
9. The console will say, "Prepare to launch. Ready..."
10. You will hear rising tones for a few seconds – use this time to focus your concentration and get it as high as you can.
11. The console will then begin a countdown – "5, 4, 3, 2, 1." During this countdown, try to maintain your concentration at the highest level you can.
12. When the countdown reaches zero, the puck will launch. The distance it travels is based on the average strength of your concentration level during the countdown phase. The higher the average, the further the puck will travel.
13. The console will award you a score based on the distance traveled. If you reach the opposite end zone, you will receive a perfect score of 420 points.

## COMPETITIVE MODE

1. Player One puts on Headset 1 and Player Two puts on Headset 2 as described in the Quick Start section.
2. Players position themselves at opposite ends of the console – Player One on the side marked with an orange "1" and Player Two on the side marked with a green "2."
3. Place the ball on the puck.
4. Turn on the console.
5. When the console says, "Select game," press the TOGGLE button until you hear "Cortex Collision" then press ENTER.
6. When the console says, "Select mode," press the TOGGLE button until you hear "Competitive" then press ENTER.
7. The puck will move to Player One's side of the console.
8. The console will say, "Player One, prepare to launch. Player Two, prepare to defend. Ready..."
9. Player One will be concentrating to push the puck across the console. Player Two will be concentrating to create a mental barrier to stop the puck.
10. Rising tones will sound for a few seconds – both players should use this time to focus their concentration and get it as high as they can.
11. The console will say "Begin" then start a countdown – "5, 4, 3, 2, 1." During this countdown, both players try to maintain their concentration at the highest levels they can.
12. When the countdown reaches zero, Player One will launch the puck from one side of the console and Player Two will launch lights from the other side. The power of each is based on the average strength of that player's concentration level during the countdown phase.
13. The greater the force of the puck and the lights, the faster they travel. Wherever they collide, the puck will stop.
14. The console will award Player One a score based on the distance the puck traveled. If it reaches the opposite end zone, Player One will receive a perfect score of 420 points.
15. The puck will then move to Player Two's side of the console and the game will prompt, "Player Two, prepare to launch..."
16. Both players repeat the steps above – this time Player Two will be concentrating to push the puck and Player One to stop it.
17. The console will announce Player Two's score and then declare a winner.

# BASKETBLASTER™

**Number of Players:** 1-2

**Modes:** Solo, Competitive

**Object:** Score as many points as you can by blasting the ball into the basket!

You will want to use all 4 balls for this game in case one rolls off the table.

## SOLO MODE

1. Attach the cannon and basket to the console so they are facing each other – the greater the distance between them, the greater the challenge (see BUILDING A COURSE for tips on setting up the basket). **NOTE:** The cannon **MUST** be plugged into the second set of holes on Player One's side of the console, but the basket can be positioned anywhere you wish.

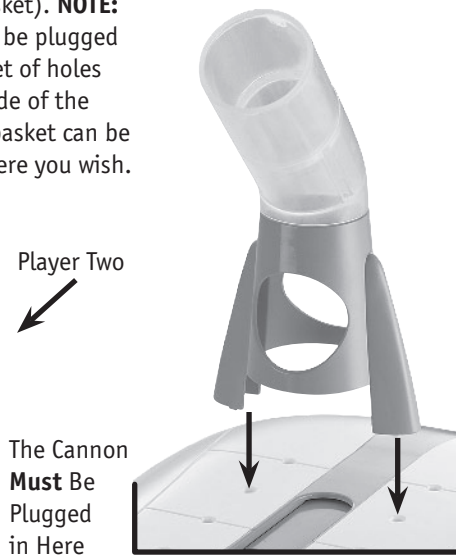

2. Put on Headset 1 as described in the Quick Start section.
3. Position yourself on Player One's side of the console.
4. Do NOT set up any other obstacles.
5. Turn on the console.
6. When the console says, "Select game," press the TOGGLE button until you hear "Basketblaster™" then press ENTER.
7. When the console says, "Select mode," press the TOGGLE button until you hear "Solo," then press ENTER.
8. After calibrating, the puck will move to Player One's side, directly under the cannon. You will not be able to move it from this position during the game.
9. The console will say, "Ready? Begin."
10. Concentrate to build up energy then push the ball into the base of the cannon to shoot.
11. Whenever the ball lands in the basket, press the ENTER button to add 1 point to your score.

12. After each shot, pick up the ball, concentrate to build up energy then push the ball into the base of the cannon to shoot again.

13. Play until your time runs out. The game will announce your score.

## COMPETITIVE MODE

**NOTE:** In Competitive Mode, the player who isn't shooting should return the balls to the shooter after each shot – they will be bouncing all over the place!

1. Attach the cannon and basket to the console so they are facing each other (as described in Solo Mode above).
2. Player One puts on Headset 1 and Player Two puts on Headset 2 as described in the Quick Start section.
3. BOTH players position themselves on Player One's side.
4. Do NOT set up any other obstacles.
5. Turn on the console.
6. When the console says, "Select game," press the TOGGLE button until you hear "Basketblaster™" then press ENTER.
7. When the console says, "Select mode," press the TOGGLE button until you hear "Competitive," then press ENTER.
8. After calibrating, the puck will move to Player One's side directly under the basket. You will not be able to move it from this position during the game.
9. The console will say, "Player One – ready? Begin."
10. Concentrate to build up energy for your shot then push the ball into the base of the cannon to shoot.
11. Whenever the ball lands in the basket, press the ENTER button to add 1 point to that player's score.
12. After each shot, pick up the ball, concentrate to build up energy then push the ball into the base of the cannon to shoot again.
13. Play until time runs out. The console will announce Player One's score.
14. Next, the console will say, "Player Two – ready?"
15. Player One and Player Two switch places, then Player Two presses ENTER and the console will say, "Begin."
16. Player Two then takes his turn and shoots the ball from the cannon to the basket, trying to score as many points as he can before time runs out.
17. Whenever the ball lands in the basket, press the ENTER button to add 1 point to Player Two's score.
18. When time is up, the console will announce Player Two's score then declare a winner based on whoever has the most points.

# TROUBLESHOOTING

## CONNECTION PROBLEMS

If you receive the message “Check headset sensor,” make the following adjustments. Be sure to wait about 5 seconds after each adjustment to see if the issue has been corrected – if so, you will hear “Calibrating headset.”

- Make sure the sensor is pressed tight and flat against your forehead. Adjust the headband if necessary.
- Make sure no hair is caught between the sensor and your skin.
- Move the forehead sensor to a slightly different position above your left eye.
- Remove then reattach the clip to your ear.
- Make sure the clip is pressed flat against your ear lobe.
- Leaving the headset on your head, turn the headset off and back on.
- Visit [www.mindflexgames.com](http://www.mindflexgames.com) for additional help.

**NOTE: If you receive the message “Check headset sensor” during a game, the game timer will pause until you reestablish a good connection.**

When exposed to an electrostatic source, the product may malfunction and suffer memory loss. If this occurs, reset the product by turning the console off then on.

## PROBLEMS CONTROLLING THE BALL

If you have difficulty controlling the ball – either raising or lowering it – try the following adjustments.

- Refer to the Concentration and Relaxation tips on pages 3.
- Turn off the headset. Place both feet flat on the floor, sit as still as you can and try to clear your mind. After 5 seconds, turn the headset back on.

**NOTE: Don't be afraid to turn off the headset in the middle of a game. The game timer will pause until the console establishes a new connection with the headset.**

- Visit [www.mindflexgames.com](http://www.mindflexgames.com) for more tips and tutorials.

## COMPLIANCE WITH FCC REGULATIONS (VALID IN U.S. ONLY)

This device complies with part 15 of the FCC Rules. Operation is subject to the following two conditions:

- (1) This device may not cause harmful interference, and
- (2) this device must accept any interference received, including interference that may cause undesired operation.

**NOTE:** This equipment has been tested and found to comply with the limits for a Class B digital device, pursuant to Part 15 of the FCC Rules. These limits are designed to provide reasonable protection against harmful interference in a residential installation. This equipment generates, uses and can radiate radio frequency energy and, if not installed and used in accordance with the instructions, may cause harmful interference to radio communications. However, there is no guarantee that interference will not occur in a particular installation. If this equipment does cause harmful interference to radio or television reception, which can be determined by turning the equipment off and on, the user is encouraged to try to correct the interference by one or more of the following measures:

- Reorient or relocate the receiving antenna.
- Increase the separation between the equipment and receiver.
- Connect the equipment into an outlet on a circuit different from that to which the receiver is connected.
- Consult the dealer or an experienced radio/TV technician for help.

**NOTE:** Changes or modifications not expressly approved by the manufacturer responsible for compliance could void the user's authority to operate the equipment.

## BATTERY SAFETY INFORMATION

In exceptional circumstances batteries may leak fluids that can cause a chemical burn injury or ruin your product. To avoid battery leakage:

- Non-rechargeable batteries are not to be recharged.
- Rechargeable batteries are to be removed from the product before being charged (if designed to be removable).
- Rechargeable batteries are only to be charged under adult supervision (if designed to be removable).
- Do not mix alkaline, standard (carbon-zinc), or rechargeable (nickel-cadmium) batteries.
- Do not mix old and new batteries.
- Only batteries of the same or equivalent type as recommended are to be used.
- Batteries are to be inserted with the correct polarity.
- Exhausted batteries are to be removed from the product.
- The supply terminals are not to be short-circuited.
- Dispose of battery(ies) safely.
- Do not dispose of this product in a fire. The batteries inside may explode or leak.



Protect the environment by not disposing of this product with household waste [2002/96/EC]. Check your local authority for recycling advice and facilities.



© 2011 Mattel, Inc. All Rights Reserved. RADICA USA Ltd. Helpline 1-800-524-8697 or [service.mattel.com](http://service.mattel.com). Mattel, Inc., 636 Girard Avenue, East Aurora, NY 14052, U.S.A. Retain this address for future reference: Mattel U.K. Ltd., Vanwall Business Park, Maidenhead SL6 4UB. Helpline - 01628 500303. Mattel Europa, B.V., Gondel 1, 1186 MJ Amstelveen, Nederland. Mattel Australia Pty. Ltd., Richmond, Victoria. 3121. Consumer Advisory Service - 1300 135 312. Mattel East Asia Ltd., Room 1106, South Tower, World Finance Centre, Harbour City, Tsimshatsui, HK, China. Diimport & Diedarkan Oleh: Mattel SEA Ptd Ltd. (993532-P) Lot 13.5, Menara Lien Hoe, Persiaran Tropicana Golf Country Resort, 47410 PJ. Tel: 03-78803817, Fax: 03-78803867.

### CONSUMER INFORMATION

Need Assistance? Visit [service.mattel.com](http://service.mattel.com) or call 1-800-524-8697 (US and Canada only).

[SERVICE.MATTEL.COM](http://SERVICE.MATTEL.COM)

T8498-0920